

FITTING INSTRUCTION

Clamp mark in acc. with		Cables joining
ISO	PN	
1	L	Left directional lights
2	+	Rear fog lights
3	31	Ground
4	R	Right directional lights
5	58R	Right side parking lights
6	54	Stoplights
7	58L	Left side parking lights

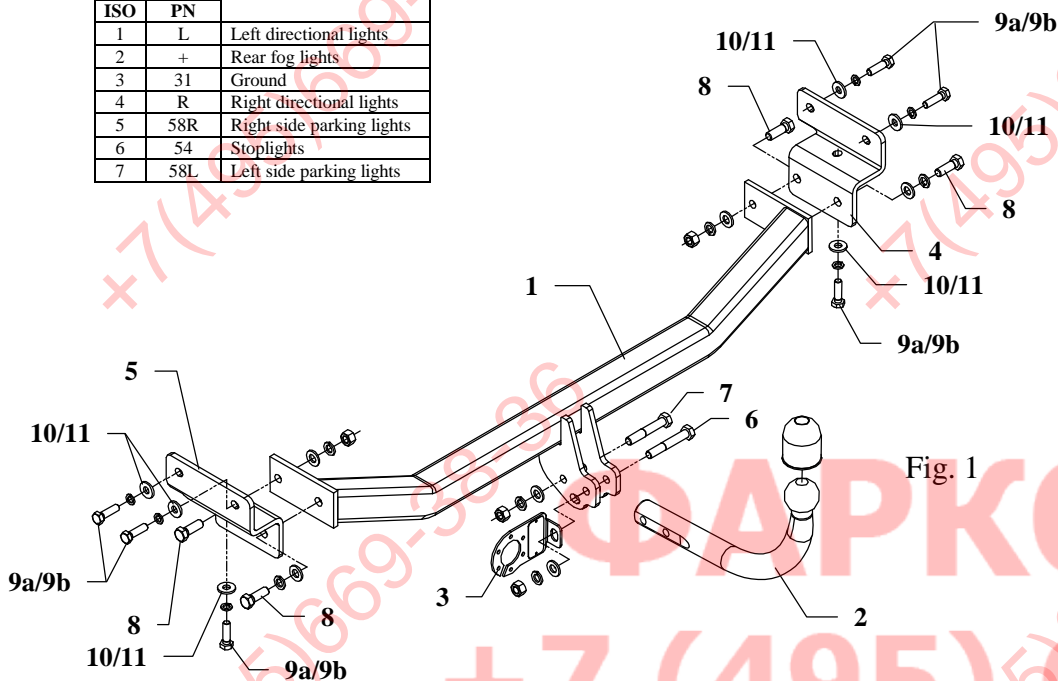

Fig. 1

This towing hitch is designed to assembly in following cars:
KIA CEE'D 3/5 doors, produced since 2006 and **HUNDAI I30 3/5 doors**,
 produced since 2007, catalogue no. **T52** and is prepared to tow trailers max
 total weight **1500 kg** and max vertical load **75 kg**.

Torque settings for nuts and bolts (8,8):	
M 8 - 25 Nm	M 10 - 55 Nm
M 12 - 85 Nm	M 14 - 135 Nm

From manufacturer

Thank you for buying our product. Their reliability has been confirmed in many tests. Reliability of towing hitch depends also on correct assembly and right operation. For this reasons we kindly ask to read carefully this instruction and apply to hints.

The towing hitch should be install in points described by a car producer.

The instruction of the assembly

1. Underneath the car disassemble plastic cover elements.
2. To chassis members fix loosely side brackets (pos. 4 and 5) as shown on the figure 1 using bolts M10x1,25x35mm (pos. 9a) or M12x1,25x35mm (pos. 9b) and big washers (pos. 10 or 11).
3. Between mounted side brackets put main bar of the towing hitch (pos. 1) and fix by bolts M12x35mm (pos. 8).
4. Tighten all bolts according to the torque shown in the table.
5. Reassemble plastic covers after cut out theirs fragments according to figure 2 below.
6. Fix tow-ball (pos. 2) with socket plate (pos. 3) using bolts M12x75mm (pos. 6) and M12x70mm (pos. 7) from accessories.
7. Connect electric wires of 7-poles socket according to the instruction of the car. (Recommend to make at authorized service station).
8. Complete paint layer damaged during installation.

Fig. 2. Covers' cut out

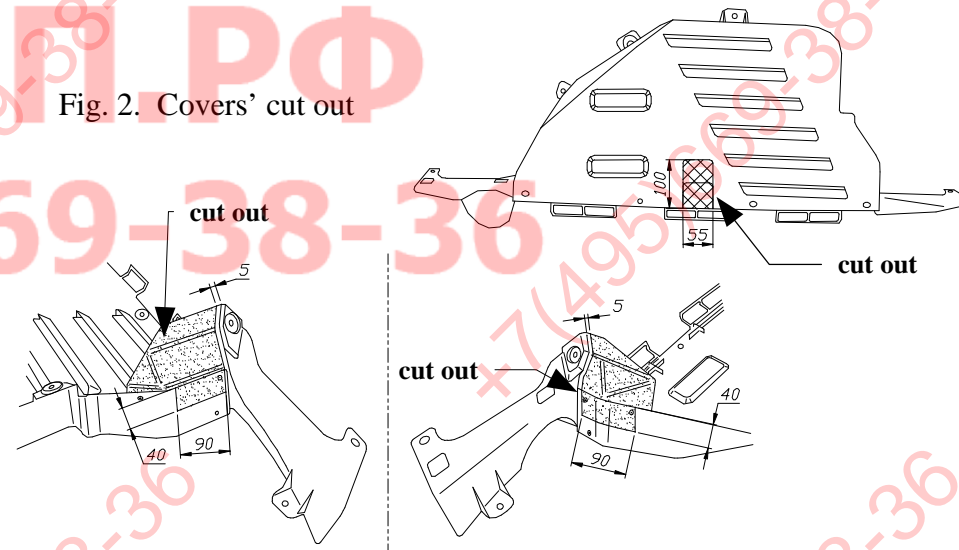











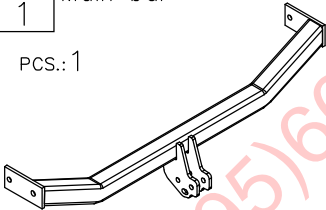
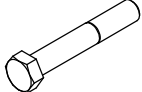

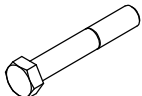
NOTE

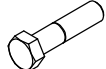
After install the towing hitch you should get adequate note in registration book (at authorised service station).The car should be equipped with:

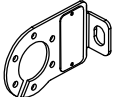
- Indicators
- Tow mirrors

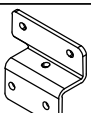
After 1000km of exploitation check all bolts and nuts. The ball of towing hitch must be always kept clear and conserve with a grease.

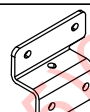
Towing hitch accessories:

Pos. 1 Main bar PCS.: 1		Pos. 6 Bolt 8,8 B M12x75mm PCS.:1		Pos. 11 Washer ø30xø10.5x2.5mm PCS.:6	
		Pos. 7 Bolt 8,8 B M12x70mm PCS.:1		Pos. 12 Plain washer ø12mm PCS.:12	
Pos. 2 Tow ball PCS.:1		Pos. 8 Bolt 8,8 B M12x35mm PCS.:4		Pos. 13 Spring washer ø12mm PCS.:6	
Pos. 3 Socket plate PCS.: 1		Pos. 9a Bolt 8,8 B M12x1,25x35mm PCS.:6		Pos. 14 Spring washer ø10mm PCS.:6	
Pos. 4 Right bracket PCS.: 1		Pos. 9b Bolt 8,8 B M10x1,25x35mm PCS.:6		Pos. 15 Nut 8 B M12 PCS.:4	
Pos. 5 Left bracket PCS.: 1		Pos. 10 Washer ø37xø13x3mm PCS.:6		Pos. 16 Ball cover PCS.:1	



PPUH AUTO-HAK S.J.

Produkcja Zaczepów Kulowych
Henryk & Zbigniew Nejman
76-200 SŁUPSK ul. Słoneczna 16K
tel/fax (059) 8-414-414; 8-414-413
E-mail: office@autohak.com.pl
www.autohak.com.pl

Towing hitch (without electrical set)

Class: **A50-X** Cat. no. **T52**

Designed for:

Manufacturer: **KIA**

Model: **cee'd**

Type: **3/5 doors**

produced since 2006 and

Manufacturer: **HYUNDAI**

Model: **I30**

Type: **3/5 doors**

produced since 2007

Technical data:

D-value: 8,3 kN

maximum trailer weight: **1500 kg**

maximum vertical cup load: **75 kg**

Approval number according to Directive 94/20/EC: e20*94/20*0280*00

Foreword

This towing hitch is designed according to rules of safety traffic regulations. The towing hitch is a safety component and can be install only by qualified personnel. Any alteration or conversion of the towing hitch is prohibited and would lead to cancellation of design certification. Remove insulating compound and underseal from vehicle (if present) in the area of the matting surfaces of the towing hitch. The vehicle manufacturer's specifications regarding trailer load and max. vertical cup load are decisive for driving whereat values for the towing hitch cannot be exceeded.

D-value formula:

$$\frac{\text{Max trailer weight [kg]} \times \text{Max vehicle weight [kg]}}{\text{Max trailer weight [kg]} + \text{Max vehicle weight [kg]}} \times \frac{9,81}{1000} = D \text{ [kN]}$$